

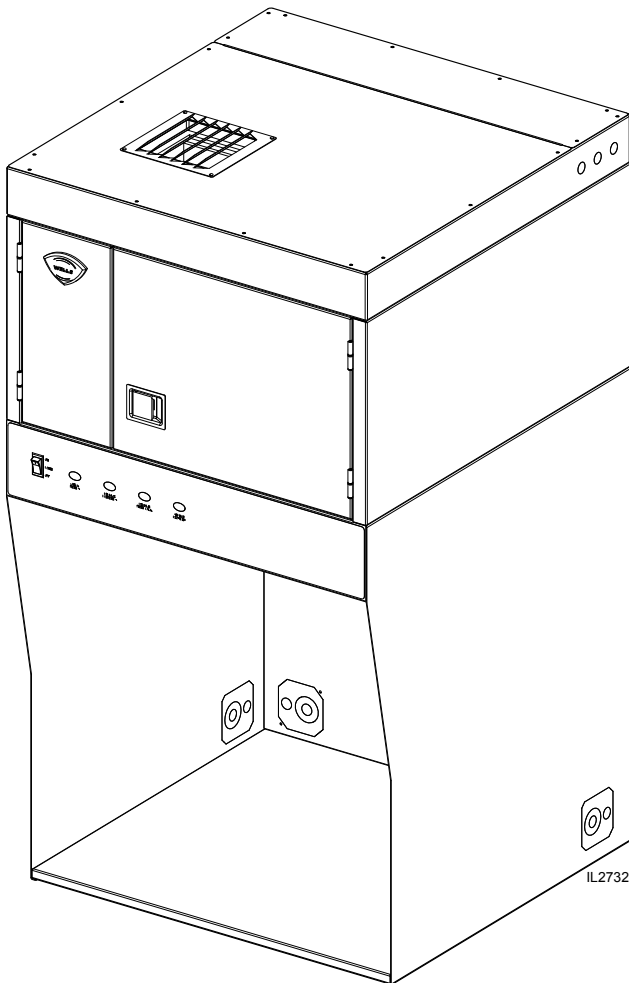

WELLS MANUFACTURING

265 Hobson Street, Smithville, Tennessee 37166
telephone: 800-264-7827
www.wells-mfg.com

524



OWNERS MANUAL

**COUNTERTOP
VENTLESS UNIVERSAL
HOOD SYSTEM**
for
**COUNTERTOP ELECTRIC
APPLIANCES**

MODEL WVU-31CT

Manual Includes
**INSTALLATION
USE & CARE
EXPLODED VIEW
PARTS LIST
WIRING DIAGRAM**

IMPORTANT: DO NOT DISCARD THIS MANUAL

This manual is considered to be part of the appliance and is to be given to the OWNER or MANAGER of the restaurant, or to the person responsible for TRAINING OPERATORS of this appliance. Additional manuals are available from your WELLS DEALER.

THIS MANUAL MUST BE READ AND UNDERSTOOD BY ALL PERSONS USING OR INSTALLING THIS APPLIANCE. Contact your WELLS DEALER if you have any questions concerning installation, operation or maintenance of this equipment.

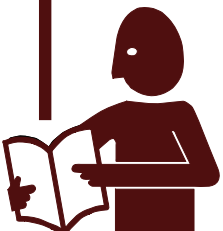

LIMITED EQUIPMENT WARRANTY

Wells Manufacturing warrants to the original purchaser of new Wells products to be free from defects in material or workmanship, under normal and proper use and maintenance service as specified by Wells and upon proper installation and start-up in accordance with the instructions supplied with each Wells unit. Wells’ obligation under this warranty is limited to a period of one [1] year beginning from the date of original installation. The warranty period begins upon the earlier of the date of original installation or up to six [6] months after the original shipment, from the factory, of the covered product. Defects that occur as a result of normal use, within the time period and limitations defined in this warranty, will at Wells’ discretion have the parts replaced or repaired by Wells or a Wells-authorized service agency.

THIS WARRANTY IS SUBJECT TO ALL LISTED CONDITIONS

Repairs performed under this warranty are to be performed by a Wells authorized service agency. Wells will not be responsible for charges incurred or service performed by non-authorized repair agencies. In all cases, the nearest Wells-authorized service agency must be used. Wells will be responsible for normal labor charges incurred in the repair or replacement of a warranted product within 50 miles (80.5 km) of an authorized service agency. Time and expense charges for anything beyond that distance will be the responsibility of the owner. All labor will need to be performed during regular service hours. Any overtime premium will be charged to the owner. For all shipments outside the U.S.A. and Canada, please see the International Warranty for specific details. It is the responsibility of the owner to inspect and report any shipping damage claims, hidden or otherwise, promptly following delivery. No mileage or travel charges will be honored on any equipment that is deemed portable. In general, equipment with a cord and plug weighing less than 50 lb. (22.7 kg) is considered portable and should be taken or shipped to the closest authorized service agency, transportation prepaid.

CONTACT

Should you require any assistance regarding the operation or maintenance of any Wells Manufacturing; phone or email our service department. In all correspondence provide the model number and serial number of the unit needing service; include the voltage or gas type.

Normal Business Hours: 8:00 a.m. to 4:30 p.m. Central

Telephone: 800-264-7827 Tech Service Option 2

Email: TechService@partstown.com

www.Wells-Mfg.com

WARRANTY EXCLUSIONS

THE FOLLOWING WILL NOT BE COVERED UNDER WARRANTY.

Wells’ sole obligation under this warranty is limited to either repair or replacement parts, subject to the additional limitations detailed below. This warranty neither assumes nor authorizes any person to assume obligations other than those expressly covered by this warranty.

- Any product which has not been used, maintained, or installed in accordance with the directions published in the appropriate installation sheet and/or owner’s manual, including incorrect gas or electrical connection. Wells is not liable for any unit which has been mishandled, abused, misapplied, subjected to harsh chemicals, modified by unauthorized personnel, damaged by flood, fire, or other acts of nature [or God], or which have an altered or missing serial number.
- Installation, labor, and job checkouts, calibration of heat controls, air and gas burner/bypass/pilot adjustments, gas or electrical system checks, voltage and phase conversions, cleaning of equipment, or seasoning of griddle surface.
- Replacement of fuses or resetting of circuit breakers, safety controls, or reset buttons.
- Replacement of broken or damaged glass components, quartz heating elements, and light bulbs.
- Labor charges for all removable and consumable parts in gas charbroilers and hotplates, including but not limited to burners, grates, and radiants.
- Any labor charges incurred by delays, waiting time, or operating restrictions that hinder a service technician’s ability to perform service.
- Replacement of parts that fail or are damaged due to normal wear or labor for replacement of parts that can be replaced during a daily cleaning routine, such as but not limited to silicone belts, PTFE non-stick sheets, control labels, knobs, bulbs, fuses, quartz heating elements, baskets, racks, and grease drawers.
- Any economic loss of business or profits.
- Non-OEM parts. Use of non-OEM parts without Wells’ approval will void the warranty.
- Units exceeding one [1] year from original installation date.

ADDITIONAL WARRANTIES

- Specific/chain-specific equipment may have additional and/or extended warranties.

The foregoing warranty is in lieu of any and all other warranties expressed or implied and constitutes the entire warranty.

PRODUCTS	PARTS	LABOR
Universal Ventless Hoods (WVU)	1 year	1 year
Canopy Ventless Hoods (WVC)	1 year	1 year
*Universal ventless hoods and/or canopy ventless hoods purchased with approved Star Holdings electric equipment. **Star Holdings approved electric equipment purchased and installed a under ventless hood. *** Universal ventless hood and Star Holdings electric equipment must be on the same po and listed on the ventless start-up document for the 2-year warranty to apply.	2 years	2 years
"Cook'n Hold equipment (HW-106D)	2 years	2 years
Cast iron gates, burners and burner shields	1 year	
Original Wells parts sold to repair Wells equipment	90 days	

TABLE OF CONTENTS

WARRANTY	xi
ELECTRICAL SPECIFICATIONS	1
WARNINGS - ENGLISH	2
WARNINGS - FRENCH	3
CLEARANCES	4
FIRE SUPPRESSION SYSTEM	5
FEATURES & OPERATING CONTROLS	6-7
PRECAUTIONS & GENERAL INFORMATION	8
INSTALLATION	9
Unpacking & Inspection	9
Components	9
Under-Hood Appliance Limitations	10
Service Technician Installation Notes	11
Site Preparation	12
Mechanical Installation	13
Electrical Installation	14-15
ANSUL® INSTALLATION & SETUP	14-15
Fire Suppression System Installation	16
Filter Installation	17
OPERATION	18
Control Panel	18
Operation Lights	18
CLEANING INSTRUCTIONS	19-20
REQUIRED MAINTENANCE & MAINTENANCE LOGS	21-25
TROUBLESHOOTING SUGGESTIONS	26
WIRING DIAGRAM	27
EXPLODED VIEW & PARTS LIST	28-34
PARTS & SERVICE	35

INTRODUCTION

Thank You for purchasing this Wells Manufacturing appliance.

Proper installation, professional operation and consistent maintenance of this appliance will ensure that it gives you the very best performance and a long, economical service life.

This manual contains information and instructions for the ventless ventilation hood, its use and care.

For information regarding cooking appliance(s), please refer to the manufacturer's operation manual.

ELECTRICAL SPECIFICATIONS

Model	Volts	Amps	Power Supply
WVU-31CT	208/240V	1.9	For supply connection use #12 AWG copper wire only.

WARNINGS - ENGLISH

IMPORTANT: DO NOT DISCARD THIS MANUAL

This manual is considered to be part of the appliance and is to be given to the OWNER or MANAGER of the restaurant, or to the person responsible for TRAINING OPERATORS of this appliance. Additional manuals are available from your WELLS DEALER.

THIS MANUAL MUST BE READ AND UNDERSTOOD BY ALL PERSONS USING OR INSTALLING THIS APPLIANCE. Contact your WELLS DEALER if you have any questions concerning installation, operation or maintenance of this equipment.



DANGER FIRE HAZARD

Fire suppression system must be charged and certified by an authorized Ansul® distributor.

DO NOT attempt to modify or bypass the fire suppression system.

An uncontrolled fire can cause serious injury or death.

WARNING:

If the fire suppression system is discharged, a buzzer will sound continuously. The unit will remain inoperable until the fire suppression system is serviced, recharged and reset by an authorized Ansul® distributor.

NOTE:

If a REMOTE MANUAL PULL STATION is installed, moving the ventilator for any reason may cause the Ansul® system to discharge.

DANGER - DO NOT BLOCK ACCESS TO THE FIRE EXTINGUISHING MANUAL PULL.



DANGER: SUFFOCATION HAZARD

“Do not attempt to use this ventilator with gas-fired units. This ventilator will not remove products of combustion. Unvented exhaust gasses can be deadly.”



WARNING: SHOCK HAZARD

All servicing requiring access to non-insulated electrical components must be performed by a factory authorized technician.

DO NOT open any access panel which requires the use of tools. Failure to follow this warning can result in severe electrical shock.



WARNING: RISK OF INJURY

Installation procedures must be performed by a qualified technician with full knowledge of all applicable electrical codes. Failure can result in personal injury and property damage.

WARNING: SLIP AND FALL HAZARD

DO NOT operate any grease-producing cooking appliance unless the grease cup is properly installed. Oil will drip onto floor creating a slipping hazard.

WARNING:

DO NOT attempt to wash the HEPA / CHARCOAL filter pack or pre-filter. Water absorption will render the filter unusable. Use of a wet or clogged filter will cause the ventilator system to shut down. Use only new, clean Wells® Authorized Service Parts. Keep spare filter packs on hand to avoid disruptions. Service Department (800) 264-7827

Exposed surfaces can be hot to the touch and may cause burns. Allow unit to cool before cleaning or servicing.

WARNINGS - FRENCH

IMPORTANT : NE JETEZ PAS CE MANUEL

Ce manuel fait partie intégrante de l'appareil et doit être remis au PROPRIÉTAIRE, au GÉRANT du restaurant ou au responsable de la FORMATION DES UTILISATEURS. Des manuels supplémentaires sont disponibles auprès de votre concessionnaire WELLS.

TOUTE PERSONNE INSTALLANT OU UTILISANT CET APPAREIL DOIT LIRE CE MANUEL ET S'ASSURER DE L'AVOIR COMPRIS.

Veuillez contacter votre CONCESSIONNAIRE WELLS pour toute question concernant l'installation, l'utilisation ou l'entretien de cet équipement.



DANGER RISQUE D'INCENDIE

Le système anti-incendie doit être chargé et certifié par un distributeur agréé Ansul®. N'essayez PAS de modifier ou de contourner le système anti-incendie. Un feu hors de contrôle risque de provoquer des blessures graves, voire mortelles.

AVERTISSEMENT :

Une alarme sonore se déclenche en continu si le système anti-incendie est déchargé. L'unité reste inutilisable jusqu'à ce qu'un distributeur agréé Ansul® effectue son intervention, le recharge et le réinitialise.

REMARQUE :

Si un AVERTISSEUR D'INCENDIE À DISTANCE MANUEL est installé, tout déplacement du ventilateur, quel qu'en soit le motif, peut provoquer la décharge du système Ansul®.

DANGER - NE PAS BLOQUER L'ACCÈS À LA POIGNÉE DE L'EXTINCTEUR !



DANGER : RISQUE DE SUFFOCATION

“Ce ventilateur ne doit pas être utilisé avec des appareils à gaz. Il n'absorbe pas les produits de combustion. En l'absence de sortie d'aération, les gaz de combustion peuvent être mortels.”



AVERTISSEMENT : RISQUE DE DÉCHARGE ÉLECTRIQUE

Toute intervention nécessitant d'accéder à des composants électriques non isolés doit être effectuée par un technicien agréé usine.

N'ouvrez AUCUN panneau d'accès nécessitant l'utilisation d'un outil. Le non-respect de cet avertissement peut exposer à une décharge électrique sévère.



AVERTISSEMENT : RISQUE DE BLESSURE

Les procédures d'installation doivent être effectuées par un technicien qualifié ayant pleine connaissance des réglementations applicables. Le non-respect de cet avertissement peut provoquer des blessures et des dommages matériels.

AVERTISSEMENT : RISQUE DE CHUTE

N'utilisez PAS d'appareil de cuisson produisant de la graisse sans que le godet à graisse soit correctement installé. Vous risqueriez de glisser car la graisse éclabousserait le sol.

AVERTISSEMENT :

N'essayez PAS de nettoyer le filtre ou le pré-filtre HEPA ou à CHARBON. L'eau absorbée rendrait le filtre inutilisable. Un filtre humide ou colmaté provoque l'arrêt du système de ventilation. Utilisez uniquement des pièces neuves et propres, homologuées par Wells®. Conservez des filtres de rechange pour éviter l'interruption du fonctionnement.

Service clientèle : (800) 264-7827.

CLEARANCES

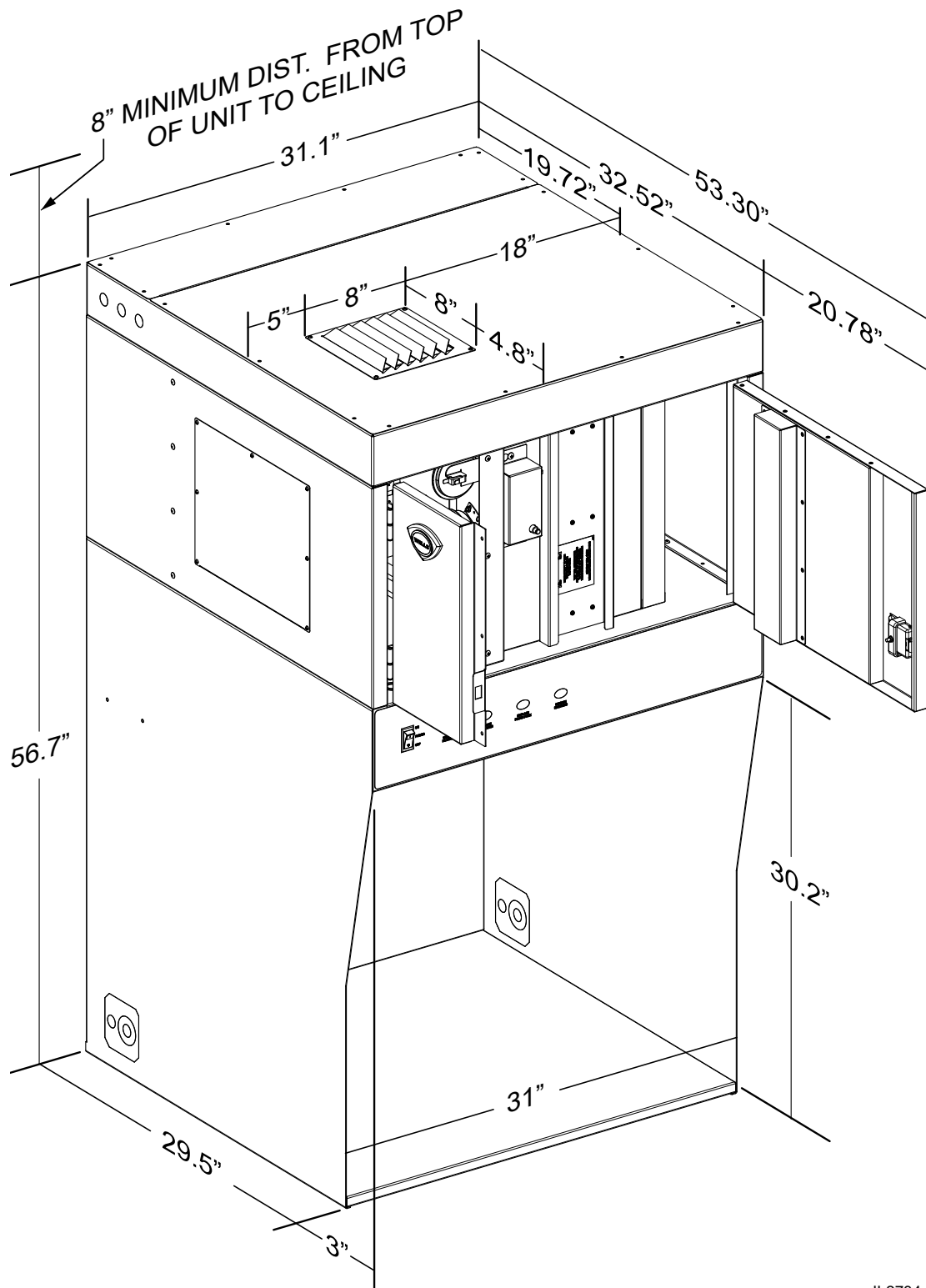

IL2734 REV A (10-23)

M524 p/n 2M-Z17951 OpM WVU- Countertop Universal Hood

FIRE SUPPRESSION SYSTEM

Fire Suppression System Installation

It is required that this unit be protected by a UL listed fire suppression system, provided by the customer. The final installation, testing and certification of the system is the responsibility of the customer and **MUST** be performed by a qualified Fire Protection Agent in accordance with the hood system.

This Wells Ventless System includes factory installed piping, plenum, discharge nozzles, thermal detectors.

A list of customer supplied Ansul® parts are listed in the **PARTS LIST** section of this manual. (See Page 34)



DANGER
DANGER
FIRE HAZARD

Fire suppression system must be charged and certified by an authorized Ansul® distributor.

DO NOT attempt to modify or bypass the fire suppression system.

An uncontrolled fire can cause serious injury or death.

NOTE:

If the fire suppression system is discharged, a buzzer will sound continuously. The unit will remain inoperable until the fire suppression system is serviced, recharged and reset by an authorized Ansul® distributor.

Charging of the Ansul® Fire Suppression system must be in accordance with Ansul® Design, Installation, Recharge and Maintenance Manual, #418087.

NOTE:

If a REMOTE MANUAL PULL STATION is installed, moving the ventilator for any reason may cause the Ansul® system to discharge.

IMPORTANT:

Should the fire suppression system discharge: all nozzles must be replaced, and all lines thoroughly cleaned, prior to recharging the system.

Residual fire suppression media may compromise the flow and dispersion of fire suppression media in any subsequent activation.

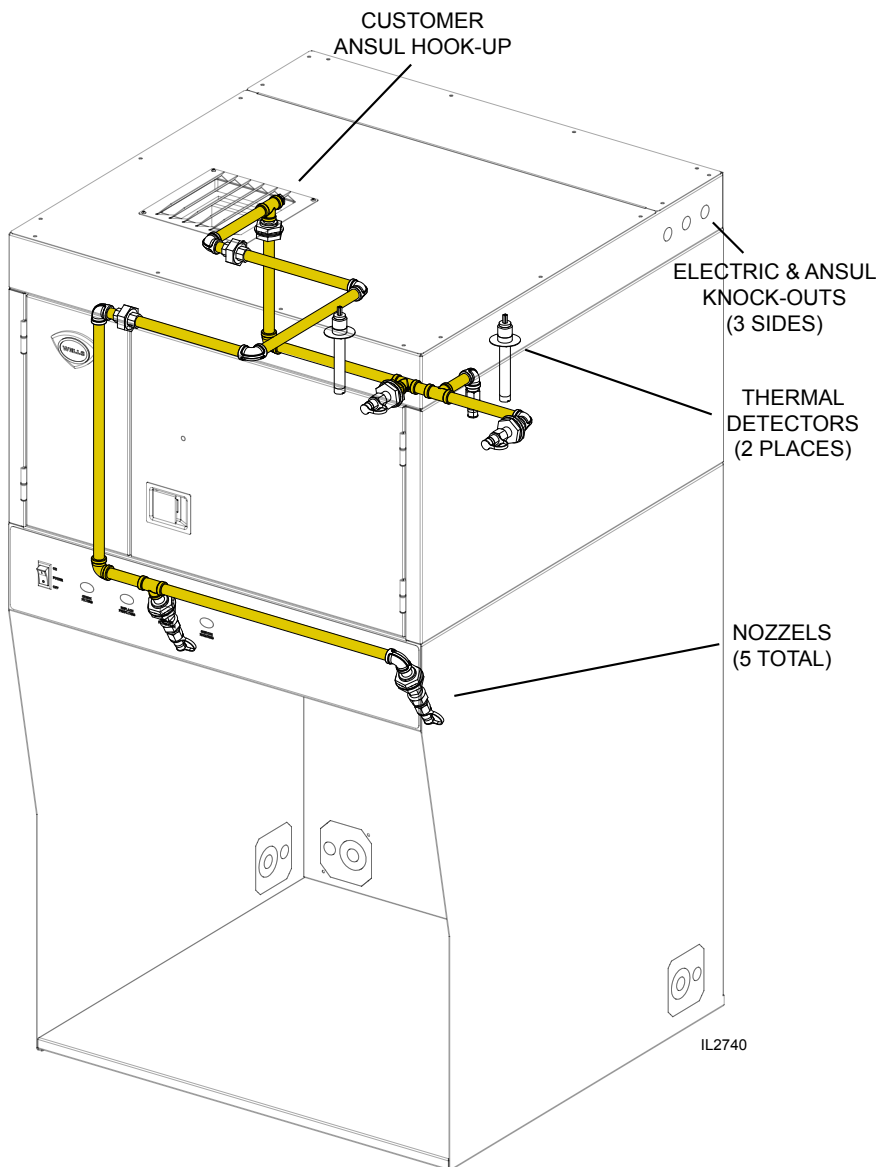

FEATURES & OPERATING CONTROLS

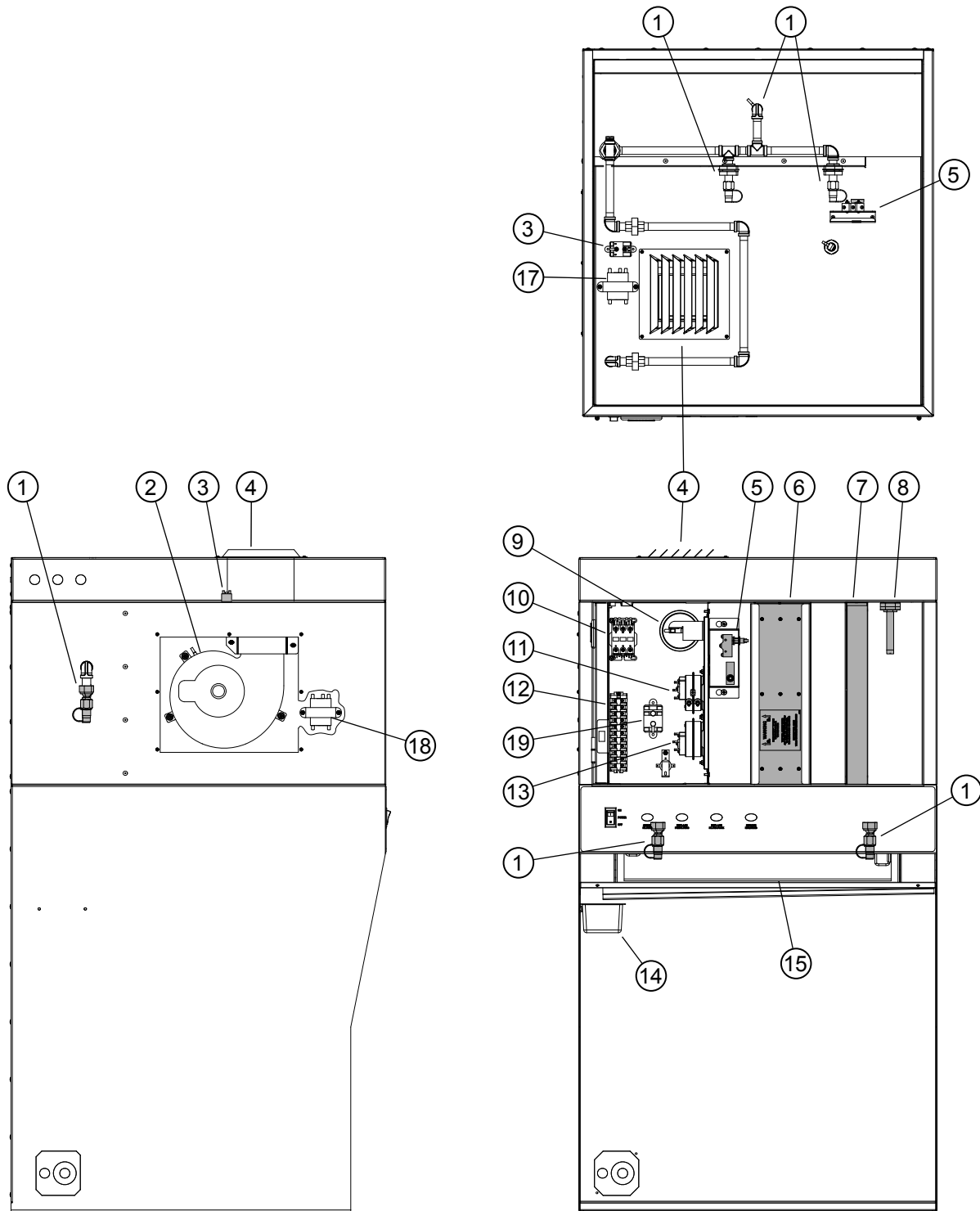

IL2735

Countertop Ventilator Section Operating Features & Controls

M524 p/n 2M-Z17951 OpM WVU- Countertop Universal Hood

FEATURES & OPERATING CONTROLS continued

FEATURES & OPERATION CONTROLS		
ITEM NO	DESCRIPTION	COMMENT
1	DISCHARGE NOZZLES	Fire suppression media discharges here, (5 places)
2	VENTILATOR FAN	Provides air movement for ventilation
3	DETECTION END OF LINE RELAY	Prevents appliance operation if a fault is found in detection circuit.
4	VENTILATOR EXHAUST DUCT, FRONT	Exit point for ventilator airflow - on front of unit. DO NOT BLOCK
5	FILTER INTERLOCK SWITCHES	Proper installation of baffle filter and filter pack closes these switches in ventilator sensor circuit
6	HI-EFFICIENCY/CHARCOAL FILTER PACK	Removes grease and smoke particles. Also assists in cooking odor removal.
7	PRE-FILTER	Replaceable PRE-FILTER, stops large particles of grease from reaching the FILTER PACK for reduced maintenance costs.
8	ELECTRICAL DETECTORS	Designed to activate at a certain temperature. Activates (i.e. fire on the cooktop) activates fire suppression system. Should be checked every 6 months during ANSUL® Service Inspection
9	PRE-FILTER SWITCH	Monitors the Pre-Filter and indicates when it needs replacing, if ignored it will lead to unit shut down.
10	EQUIPMENT INTERFACE CONTACTOR	Energizes cooking appliances only while ventilator section is sensed as operational.
11	HEPA FILTER SWITCH	Monitors the HEPA filter and indicates when it needs replacing, if ignored it will lead to unit shut down.
12	SUPPLY CONNECTION TERMINAL BLOCK	Provides connection point for electrical circuitry
13	UNIT SHUT-DOWN SWITCH	Shuts down the unit and appliances when the lack of air flow reaches a certain level, triggers a service unit indicator.
14	GREASE DRIP TRAY	Collects grease/moisture dripping from baffle filter (16)
15	BAFFLE FILTER	Extracts and drains most greases and moisture from the air flow.
16	APPLIANCE LIGHT (Not Shown)	ON when hood power switch is ON. Illuminates cooking area.
17	120V TRANSFORMER	Provides power to appliance lights
18	120V TRANSFORMER	Provides power to contactor relay
19	BUILDING ALARM RELAY	Provides electrical connections for building alarm system

PRECAUTIONS AND GENERAL INFORMATION



DANGER: **SUFFOCATION HAZARD**

Do not attempt to use this ventilator with gas-fired units. This ventilator will not remove products of combustion. Unvented exhaust gasses can be deadly.



WARNING: **SHOCK HAZARD**

All servicing requiring access to non-insulated electrical components must be performed by a factory authorized technician.

DO NOT open any access panel which requires the use of tools. Failure to follow this warning can result in severe electrical shock.

IMPORTANT:

The ventilator is disabled when the filters are plugged to the point of insufficient airflow for proper operation. Also, power to the cooking appliances is interrupted if any filters or service panel are removed.

It is the responsibility of the store management to maintain sufficient spares of filter packs to avoid prolonged shutdown due to a dirty or clogged filter pack. Filter packs cannot be cleaned.

Wells Manufacturing assumes no liability for loss of business due to a filter related shutdown. Spare filters can be purchased from any authorized Wells servicer or calling Wells.

This ventilator hood is part of an engineered system and is intended for use in commercial establishments only.

This ventilator is intended for commercial establishments for use in the preparation food for human consumption. No other use is recommended or authorized by the manufacturer or its agents.

Operators of this appliance must be familiar with the appliance use, limitations and associated restrictions. Operating instructions must be read and understood by all persons using or installing this appliance.

This ventilator hood system is designed to reduce odor emissions, but will not completely eliminate all cooking odors. Air exchange rates at the installation site must comply with the requirements of the local jurisdictional authority. To ensure that odors do not accumulate, recommended minimum air exchange is 200 cfm per linear foot of hood into *and out of* the site.

This unit is intended for use with light- and medium duty electric cooking appliances only. Cooking appliances placed under this ventilator must comply with the restrictions set forth in the *Installation section of this manual*.

Do not connect or energize this appliance until all installation instructions are read and understood. Property damage or bodily injury may result if these instructions are not followed. Disconnect this appliance from electrical power before performing any maintenance or servicing.

Cleanliness of this appliance is essential to good sanitation. Read and follow all included cleaning instructions and schedules to ensure the safety of the food product.

This appliance is not jet steam approved. Do not direct water jet or steam jet at this appliance, or at any control panel or wiring. Do not splash or pour water on, in or over any controls, control panel or wiring. Do not attempt to wash filter packs. Water will cause their immediate failure and disable the ventilator.

Exposed surfaces of this appliance can be hot to the touch and may cause burns.

Avoid storing flammable or combustible materials in, on or near the ventilator or associated cooking appliance.

The technical content of this manual, including any wiring diagrams, schematics, parts breakdown illustrations and/or adjustment procedures, is intended for use by qualified technical personnel.

Any procedure which requires the use of tools must be performed by a qualified technician.

All supplied instructions, diagrams, schematics, parts breakdown illustrations, notices and labels must remain with the appliance if the unit is sold or moved to another location.

This appliance is made in the USA. Unless otherwise noted, this appliance has American sizes on all hardware.

INSTALLATION

UNPACKING & INSPECTION

Carefully remove the appliance from the carton. Remove all protective plastic film, packing materials and accessories from the appliance before connecting electrical power or otherwise performing any installation procedure.

Carefully read all instructions in this manual and any other documents packed with the appliance before starting any installation. All documentation should remain with the equipment operator for future reference.

Read and understand all labels and diagrams attached to the ventilator.

Carefully account for all components and accessories before discarding packing materials.

COMPONENTS

Pre-Filter	1 ea.
Baffle Filter	1 ea.
Filter pack	1 ea.
Grease cup	1 ea.

Ansul® components - must be supplied by customer and installed by an authorized Ansul® distributor only:

The unit is shipped with an angled discharge grill.

To change the direction of the discharge airflow:

1. Remove the discharge grill by removing the four (4) mounting screws on the grill.
2. Rotate the discharge grill to the desired discharge position.
3. Re-Secure the grill using the four (4) mounting screws.

NOTE: DO NOT discard the carton or other packing materials until you have inspected the appliance for hidden damage and tested it for proper operation. Refer to *SHIPPING DAMAGE CLAIM PROCEDURE* on the inside front cover of this manual.

WARNING:

Risk of injury

Installation procedures must be performed by a qualified technician with full knowledge of all applicable electrical codes. Failure can result in personal injury and property damage.



IMPORTANT:

Fire suppression system must be charged and certified by an authorized Ansul® distributor. Ventilator will not operate and cooking appliance will not be energized until the Ansul® fire suppression system has been charged.

IMPORTANT:

After cooking appliances are positioned under the hood, swivel nozzles must be positioned per Ansul® recommendations.

INSTALLATION (continued)

UNDER-HOOD APPLIANCE LIMITATIONS:

1. Appliance must be installed per manufactures instructions.
2. Electrical appliances only. Not Intended for gas fired units.
3. All appliances under the hood must be connected to the hood appliance interlock circuit.
4. All appliances must meet the requirements outlined in the cooking appliance limitations chart below.

EQUIPMENT PARAMETER WVU-31CT						
Coverage Parameters	Maximum kW / Ft	Maximum Cooking Temperature	Maximum Single Appliance Heated Cooking Surface	Dim A, Minimum (1)	Dim B, Minimum (2)	Dim B, Maximum (3)
Appliance Type						
Fryer*	16.9	400°F (204°C)	24	5	12	20
Griddle	5.5	450°F (232°C)	24	5	12	20
Hotplate	5.5	N/A	N/A	5	15	25
Counter Top Oven	N/A	550°F (287°C)	27	4	5	N/A
Sandwich Grills	5.5	450°F (232°C)	24	5	10	25
Convection Oven	N/A	550°F (287°C)	27	5	5	N/A
Micro Combi Oven	N/A	550°F (287°C)	27	4	5	N/A

* Clearances to heated surface for fryer use shall be measured to the oil fill line

(A) FRONT OF HOOD TO FRONT EDGE OF HEATED COOKING SURFACE.

(B) BOTTOM FRONT EDGE OF HOOD TO HEIGHT OF HEATED COOKING SURFACE.

The hood and all under hood appliances must be installed in accordance with the standard for ventilation control and fire protection of commercial cooking operations NFPA 96, the national electric code NFPA 70 and all local codes where applicable.

All under hood appliances must be controlled by the equipment shutoff interface. Only electrically heated appliances are acceptable for installation. Appliance operation requires the fire suppression system be setup, charged and certified by an authorized ansul® distributor. The airflow monitoring system will prevent appliance operation if insufficient airflow is detected or all filters are not in place. The service panel must be in place for blower operation.

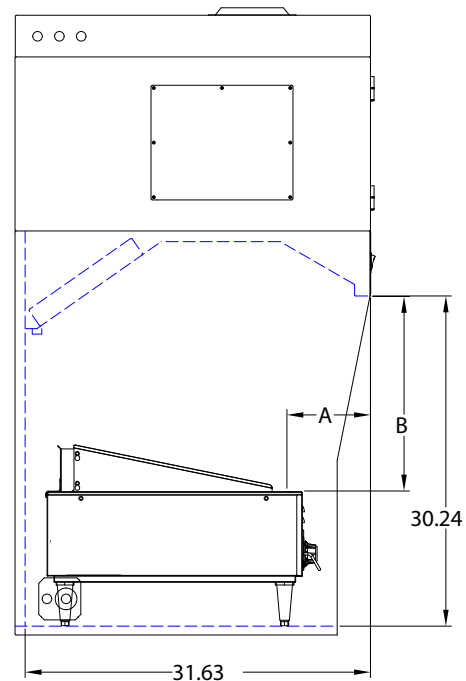

Clearances to heated surface for fryer use shall be measured to the oil fill line

SIDE VIEW

SK3205 REV - (10-23)

WELLS MANUFACTURING
 MODEL NO: WVU-31CT
 LOWER AIR FLOW LIMIT: 375CFM
 MAXIMUM MEASURED GREASE EMISSIONS: .000693 LB/HR/FT
 ANSI-UL710B RECIRCULATING SYSTEM

M524 p/n 2M-Z17951 OpM WVU- Countertop Universal Hood

INSTALLATION (continued)

SERVICE TECHNICIAN INSTALLATION NOTES

This ventilator hood is to be used with light-duty and medium-duty electrically powered cooking appliances only.

- DO NOT attempt to use this ventilator hood with gas-fired units.
- DO NOT use this ventilator hood with electrical appliances whose dimensions or wattage characteristics exceed those defined in the Under Hood Cooking Appliance Limitations, page 10.

Installation and start up must be performed by an Authorized Installation Company.

Ansul® Installer must complete the WARRANTY INITIATION form (2M-303912) included with the unit for the warranty to begin, and record installation particulars on the CUSTOMER SERVICE DATA form located at the end of this manual.

It is the responsibility of the installer to verify that this VENTILATOR installation is in compliance with the specifications listed in this manual, with local code requirements, and in accordance with NFPA 96 the STANDARD FOR VENTILATION CONTROL AND FIRE PROTECTION OF COMMERCIAL COOKING OPERATIONS.

WARNING: IMPROPER INSTALLATION, ADJUSTMENT, ALTERATION, SERVICE OR MAINTENANCE CAN CAUSE PROPERTY DAMAGE, INJURY OR DEATH. READ THE INSTALLATION, OPERATION AND MAINTENANCE INSTRUCTIONS THOROUGHLY BEFORE INSTALLING OR SERVICING THIS EQUIPMENT.

WARNING: THIS PRODUCT IS NOT PROVIDED WITH AN INTEGRAL FIRE EXTINGUISHING SYSTEM. AUTHORITIES HAVING JURISDICTION SHOULD BE CONSULTED AS TO THE REQUIREMENT FOR THIS EQUIPMENT WITH RESPECT TO FIRE EXTINGUISHING SYSTEMS, SUCH AS THE NEED FOR FIELD INSTALLED SYSTEMS IN ACCORDANCE WITH NFPA 96.



DANGER: **SUFFOCATION HAZARD**

Do not attempt to use this ventilator with gas-fired units. This ventilator will not remove products of combustion. Unvented exhaust gasses can be deadly.



WARNING: **SHOCK HAZARD**

All servicing requiring access to non-insulated electrical components must be performed by a factory authorized technician.

DO NOT open any access panel which requires the use of tools. Failure to follow this warning can result in severe electrical shock.



CAUTION: **RISK OF DAMAGE**

DO NOT connect or energize this appliance until all installation instructions are read and followed. Property damage or bodily injury could result if these instructions are not followed.

IMPORTANT:

If a remote pull station is to be used, ventilator cannot be moved without first disabling the remote pull station.

Contact your Ansul® agent for details.

INSTALLATION (continued)

Site Preparation

1. Provide clearance around installation site to safely lift equipment into its final position. Consider general service and installation space when locating unit.
2. Thoroughly review the plans and specification of the project.
3. Determine the exact location in which the cooking hood will be installed and verify that there are no interferences, which will prevent proper installation. There should be a necessary amount of space above the hood for proper air discharge.
4. This unit is designed to sit on a permanent level counter, at no time should this unit be in operation on a movable cart. Ensure the site is capable of supporting both the hood's weight as well as the appliance.
5. Determine if adequate room is available to install the hood with proper clearance from combustible material. IMC, NFPA96 and local authorities having jurisdiction call for a minimum clearance (typically 18 inches) between the cooking hood(s) and building materials, which are combustible. However, IMC and NFPA96 outline acceptable clearance reduction methods. It is important to check with the local authority having jurisdiction to determine that the installation method is satisfactory to meet their requirements prior to installing the equipment.

INSTALLATION (continued)

MECHANICAL INSTALLATION

The following is a step-by-step procedure for installation of the Recirculating Hoods.

1. Uncrate the hood, being very careful not to dent or scratch the outer surface. **NOTE:** Report any damage to the delivering freight carrier and file a claim if appropriate. Check the nameplate on the equipment to make certain it meets the specifications provided by the architect and or engineer. If discrepancies exist, notify the manufacturer immediately.
2. It's important that you have read and understand "Site Preparation" before continuing with the installation of the hood. See Table on page 8 "EQUIPMENT PARAMETER".
3. Determine the exact location of the hood.
4. Raise the hood into position using high lifts or equipment jacks.
5. Once the hood is in position, check to ensure the hood is level and stable.
6. Apply a bead of food grade silicone sealant to the entire perimeter of the hood base to the counter top. A liquid tight seal must be made between the hood base and the counter top.
7. A 5/16 inch hole is located on the rear of the unit if a tether devise (NOT SUPPLIED) is required.
 - a) Remove the plug by prying the plug out of the hole.
 - b) Install tether device.

Electrical Knock-out

On each wall of the enclosure is a grouping of electrical connection knock outs. Each grouping consists of four (4) individual knock outs.

They are:

- 2 of diameter 0.875 inch to allow use of a 1/2 inch trade size cable connector.
- 1 of diameter 1.984 inch to allow use of a 1 1/2 inch trade size cable connector.
- 1 of a 3.8 inch by 3.8 inch knock out with two .177 diameter holes to allow use of a standard 4 inch by 4 inch electrical junction box.

Knock outs are also located on three (3) sides of the top panel. These knock outs are sized to accept a 1/2 inch trade size connection clamp.

IMPORTANT

Any appliance connection mounted to any of the enclosure wall knock outs **MUST** be sealed to the wall with high temperature silicone sealant.

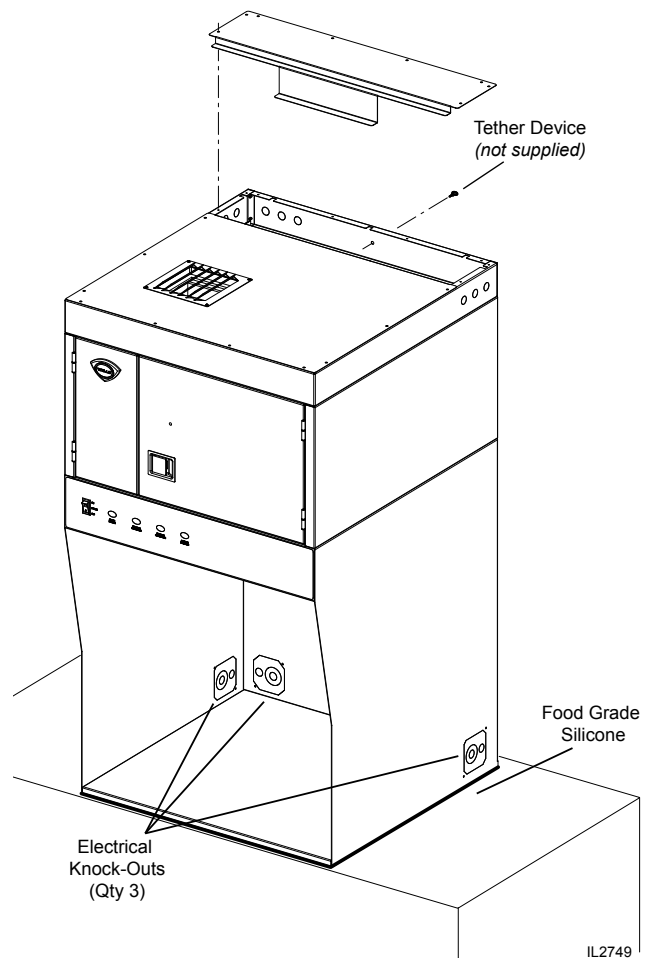

INSTALLATION



DANGER: SUFFOCATION HAZARD

Do not attempt to use this ventilator with gas-fired units. This ventilator will not remove products of combustion. Unvented exhaust gasses can be deadly.



WARNING SHOCK HAZARD

Electrical connections must be made by a licensed electrician.



CAUTION: FIRE HAZARD HEALTH HAZARD

All cooking appliance must be connected to the cooking appliance contactor, the control circuit of which is controlled by the ventilator.

Failure to control cooking appliances will provide no protection in the event of a fire, nor will cooking vapors and odors be contained in the event of ventilator hood malfunction.

ELECTRICAL INSTALLATION

Refer to the nameplate on the ventilator. Verify ELECTRICAL SERVICE POWER. Voltage and phase must match the nameplate specifications, and available electrical service amperage must meet or exceed the listed amperage. Refer to specifications listed on page 1 of this manual.

The ground lug of this ventilator must be connected to a suitable building ground.

Open the front control panel to access the cooking appliance contactor. Wire the cooking appliance control circuit to the terminal block per the figure below.

NOTE: It is the responsibility of the electrical contractor to provide suitable wiring, flexible or rigid conduit, and an appropriate strain relief.

Electrical Connection

NOTE: The hood requires a single phase (1ph), 208 or 240 volt, 15 amp supply. When connecting line voltage to the unit's terminal block, use a minimum of #12 gage copper wire only, suitable for 167°F (76°C) ambient temperature.

Appliance Connections

All under hood appliances are required to be interlocked with the hood's equipment cut-off circuit, through a customer supplied contactor. This contactor must be a UL listed, definite purpose AC resistive air heating type, suitable for the appliance load. Installation and connections shall be in accordance with the National Electric Code NFPA 70. These connections provide an automatic shutdown of the appliance when the hood is OFF, or in the event of a malfunction or appliance fire.

Equipment Cutoff Connections

- Opt 1: Use TB#3 & TB#4 for 208 or 240 volt control circuit. These contacts will be de-energized when the hood is OFF or in the event of a malfunction
- Opt 2: Use TB#5 & TB#6 as a Normally Closed SPST relay connection for equipment control circuits with voltages other than 208 or 240 AC. These contacts will be open when hood is OFF or in the event of a malfunction.

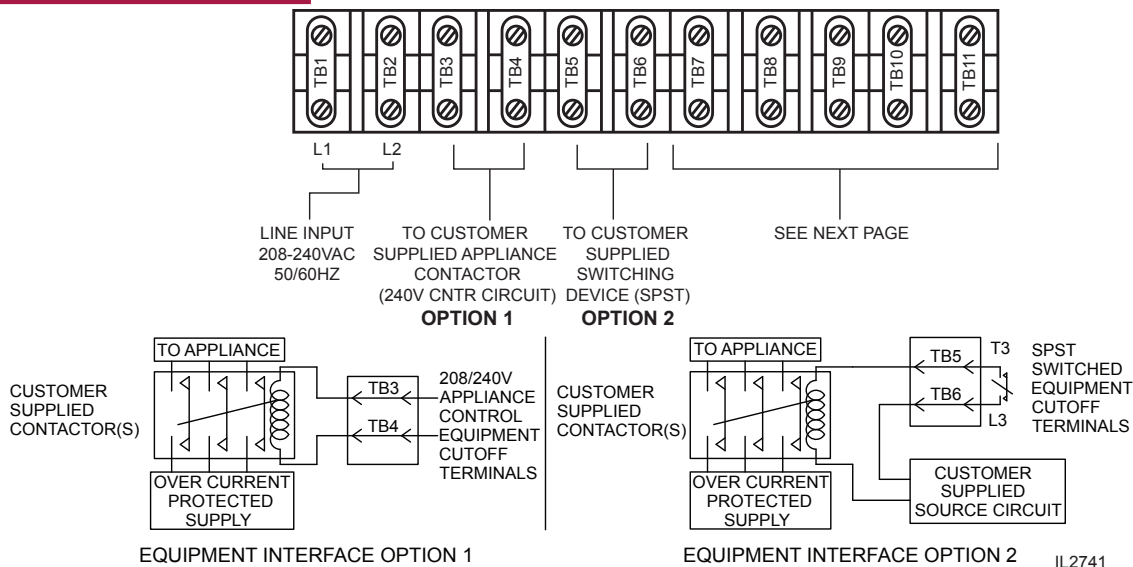

INSTALLATION continued

The ventilator will operate properly, and the appliance control relay will be energized, only when:

1. The VENTILATOR POWER SWITCH is "ON".
2. The Ansul® Fire Suppression System is charged and armed.
3. All filters are in position and serviceable, and the ventilator air flow system is satisfied.

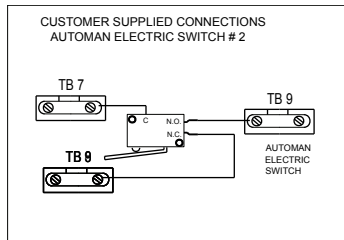
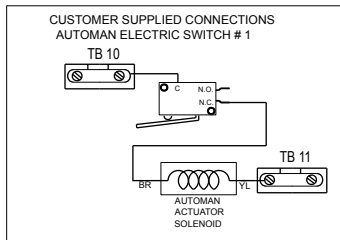

IL2742



Fire suppression system must be charged and certified by an authorized Ansul® distributor.

DO NOT attempt to modify or bypass the fire suppression system.

An uncontrolled fire can cause serious injury or death.

NOTE:

If the fire suppression system is discharged, a buzzer will sound continuously. The unit will remain inoperable until the fire suppression system is serviced, recharged and reset by an authorized Ansul® distributor.

Charging of the Ansul® Fire Suppression system must be in accordance with Ansul® Design, Installation, Recharge and Maintenance Manual, #418087.

NOTE:

If a REMOTE MANUAL PULL STATION is installed, moving the ventilator for any reason may cause the Ansul® system to discharge.

IMPORTANT:

Should the fire suppression system discharge: all nozzles must be replaced, and all lines thoroughly cleaned, prior to recharging the system.

Residual fire suppression media may compromise the flow and dispersion of fire suppression media in any subsequent activation.

INSTALLATION continued



DANGER BURN HAZARD

Any additional remote pull station must **NOT** be installed on the front of the cooking appliances,

Discharge of the fire extinguishing system into hot grease or oil may cause hot foam to spill over from the cooking surface or frypot.

Serious burns and other injuries can result from contact with hot oil and from slipping in spilled oil.

The manual pull station is installed on the right side (facing the unit). It may, however, be relocated to the left side of the ventilator hood by an authorized Ansul® agent.

FIRE SUPPRESSION SYSTEM INSTALLATION

THE FIRE SUPPRESSION SYSTEM is supplied by the customer with the exception of the piping, nozzles and thermal detectors.

The hood is not supplied with a field installed MANUAL PULL STATION, which must be set-up at the time of installation by an authorized Ansul® distributor.

The MANUAL PULL STATION allows for manual emergency shutdown of cooking appliance power, and actuation of the fire suppression system.

Three (5) NOZZLES disperse the fire suppression media. These nozzles protect the fan, plenum, Grease Baffle, Filter and Cooking Area.

If the ventilator is situated such that the supplied manual pull station cannot be installed or is not readily accessible, a REMOTE MANUAL PULL STATION may be required by local codes. Any such remote manual pull station must be installed by an authorized Ansul® distributor in accordance with the AUTHORITY HAVING JURISDICTION.

The fire detection system utilizes two (2) electronic thermal detector with an actuation set point of 225°F (107°C).

The signaling from the detection devices will automatically discharge the fire suppression media through all nozzles, disable the cooking appliances and cause the alarm to sound.

Fire suppression media will form an emulsion designed to both smother and cool the fuels in/on the cooking appliance.

The MANUAL PULL STATION and any similar REMOTE MANUAL

PULL STATION will activate the fire suppression system when the ring on the pull station is pulled to its full extent.

INSTALLATION

FILTER INSTALLATION

Note air flow direction arrow on filter pack. Remove old filter pack and slide new filter pack fully into the appropriate slot. Verify that the airflow arrow points toward the fan.

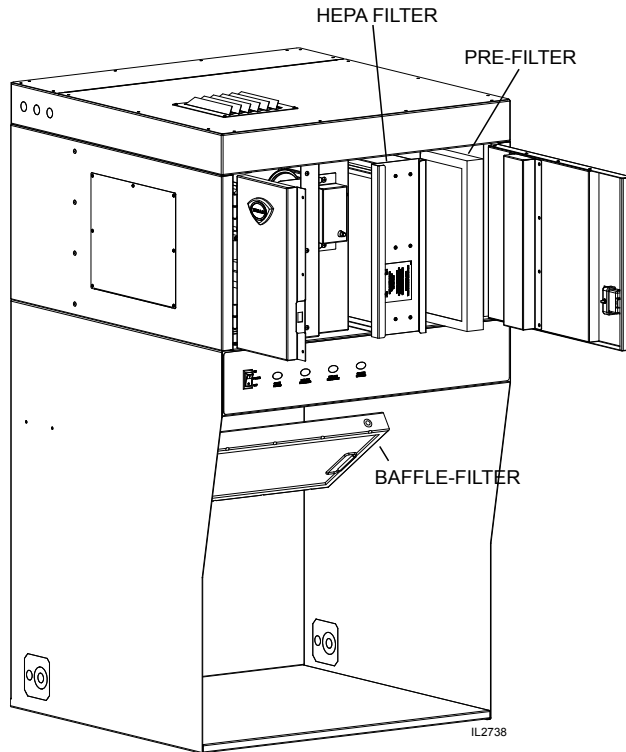

The baffle filter is reusable and should be cleaned at least weekly. Change the pre-filter and Hepa filter pack as indicated on the front panel. These filters are disposable and cannot be reusable. All filters are accessible through the front service door.

Use only genuine Wells replacement parts and filters, call (800) 264-7827 or your authorized Wells service agent. Parts supplied by others will void your warranty and may not provide safe operation.

BAFFLE FILTER and GREASE CUP INSTALLATION

1. Install baffle filter from front. Engage the baffle filter in the retainer slot. Push up until the baffle filter bottom clears the lower lip of the retainer, then lower the baffle filter into the bottom retainer
2. Install GREASE CUP into brackets below the baffle filter.

Note: Failure to install the GREASE CUP will allow grease and moisture from the BAFFLE FILTER to drop into hot cooking surfaces, creating both a SAFETY HAZARD (hot oil splatter).

NOTE:

The BAFFLE FILTERS, PRE-FILTERS and FILTER PACK actuate position switches when they are properly positioned. They must be properly installed for the under hood cooking appliance contactor to be energized.



WARNING SLIP AND FALL HAZARD

DO NOT operate any grease-producing cooking appliance unless the grease cup is properly installed. Oil will drip onto floor creating a slipping hazard.



CAUTION BURN HAZARD

DO NOT operate any cooking appliance unless the grease cup is installed.

Moisture dripping onto hot surfaces, oil or grease can cause splattering.



WARNING CLEAN FILTERS

DO NOT attempt to wash the HEPA / charcoal filter pack or pre-filter. Water absorption will render the filter unusable. Use of a wet or clogged filter will cause the ventilation system to shut down. Use only clean Wells® Authorized Service Parts. Keep spare filter packs on hand to avoid disruptions. Wells Parts Department (800) 264-7827.

OPERATION



CAUTION: HOT SURFACE

Exposed surfaces can be hot to the touch and may cause burns.



CAUTION: SHOCK HAZARD

DO NOT splash or pour water or grease onto control panel or wiring.

IMPORTANT:

The ventilator cannot operate if the filter pack is removed or clogged.

It is the responsibility of the store management to maintain sufficient spares of filter packs to avoid prolonged shutdown of the ventilator when this filter is expended.

Filter packs cannot be cleaned.

Wells Manufacturing assumes no liability for loss of business due to filter related shutdown.

Filters that are not genuine Wells Replacement Parts may cause your unit to operate incorrectly and you will risk the possibility of voiding your warranty.

Control Panel

NOTE: Cooking appliances must be operated in accordance with the manufacturer's instructions.

During normal operation, the illuminated power switch will be the only light on the control panel that will be ON.

If the CHECK FILTERS light illuminates, check BAFFLE FILTERS, PREFILTERS, and the HEPA AIR FILTERS for proper installation.

If the REPLACE PRE-FILTERS light illuminates .. Replace the Pre-filters.

If the REPLACE FILTER PACK light illuminates, replace the FILTER PACK.

NOTE: the REPLACE FILTERS PACK light is a warning that filter pack is nearing the end of its service life. The ventilator will continue to operate for a period of time after the REPLACE FILTER PACK LIGHT turns ON to allow continued operation through a peak period. However, filter pack must be replaced within a short time period or it will clog, disabling the ventilator and appliances.

If the SERVICE REQUIRED light illuminates, the filter pack is restricted to the point of insufficient airflow for proper operation and the Ventilator will shut down until the underlying clogged filter situation has been corrected. Replace clogged item with a fresh filter to correct the condition.

Reset the unit by turning VENTILATOR POWER SWITCH to OFF, then back to ON.

A failure of incoming electric power will cause a shut down of the unit. Reset the unit by turning VENTILATOR POWER SWITCH to OFF, then back to ON.

Operation Lights

There are two equipment lights that provide illumination of the working area. These lights are controlled by the main power switch.

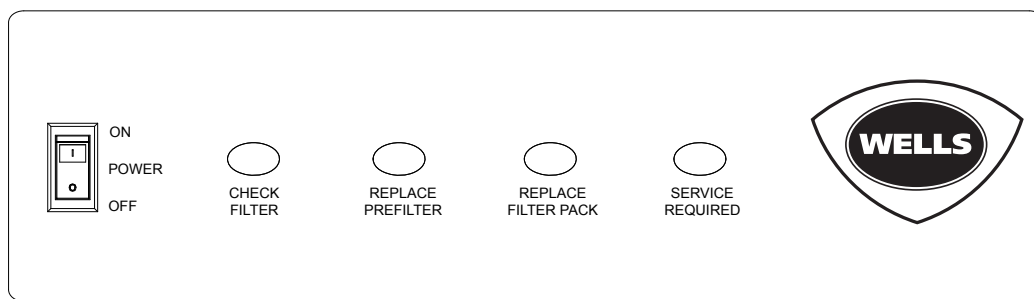

IL2736

CLEANING INSTRUCTIONS

PRECAUTIONS: Disconnect unit from electric power and allow to cool
Cover frypot to prevent oil contamination

FREQUENCY: Weekly

TOOLS: Mild detergent, clean non-abrasive towels

NOTE: Ventilator section to be cleaned in conjunction with cooking appliance. Refer to appliance user instructions for cleaning procedure.



CAUTION: HOT SURFACE

Exposed surfaces can be hot to the touch and may cause burns. Allow unit to cool before cleaning or servicing.



CAUTION: SHOCK HAZARD

DO NOT splash or pour water or grease onto control panel or wiring.

1. TURN HOOD POWER SWITCH TO OFF.
Cover cooking appliance to prevent oil contamination.
2. Remove BAFFLE FILTERS and GREASE CUP(s).
3. Empty GREASE CUP(s) into an appropriate grease collection receptacle.
4. Clean BAFFLE FILTERS and GREASE CUP(s) in a sink or dishwasher using mild detergent and warm water.
5. Dry components with a clean non-abrasive cloth.
Reinstall BAFFLE FILTERS and GREASE CUP(s) in ventilator.
6. Wipe exterior & interior surfaces of ventilator with a clean cloth moistened with warm water and mild detergent. Rinse by wiping with a clean cloth moistened with warm water.
7. Uncover the cooking appliance and reconnect unit to electric power.

Procedure is complete

WARNING

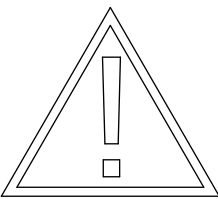

DO NOT TURN OFF HOOD DURING CLEANING OPERATIONS. SUPPRESSION SENSORS PROVIDE SUPERIOR FIRE DETECTION BUT ARE SENSITIVE TO RAPID TEMPERATURE RISE. TO PREVENT UNINTENTIONAL DEPLOYMENT OF THE FIRE EXTINGUISHING SYSTEM, DO NOT FLOOD HEATING COOKING SURFACES WITH WATER.

IL2814

CLEANING INSTRUCTIONS



CAUTION: HOT SURFACE

Exposed surfaces can be hot to the touch and may cause burns. Allow unit to cool before cleaning.

PRECAUTIONS: Disconnect unit from electric power and allow to cool. Cover cooking surfaces and frypots to prevent contamination.

FREQUENCY: Monthly

TOOLS: Mild detergent, clean non-abrasive towels



CAUTION: SHOCK HAZARD

DO NOT splash or pour water or grease onto control panel or wiring.

NOTE: Ventilator section to be cleaned in conjunction with cooking appliance. Refer to appliance user instructions for cleaning procedure.

IMPORTANT:

DO NOT wash FILTER PACK. Washing these filters will clog them, and cause installed cooking appliance to be disabled.

1. TURN HOOD POWER SWITCH TO OFF.
Cover cooking appliance to prevent oil contamination.
2. Remove BAFFLE FILTERS, GREASE CUP(s), and all FILTER PACK(s).
3. Wipe interior of ventilator with a clean cloth moistened with warm water and mild detergent. Rinse by wiping with a clean cloth moistened with warm water. DO NOT clean by spraying.
4. Dry ventilator thoroughly with a clean non-abrasive cloth.
Reinstall all FILTERS, BAFFLE FILTERS, GREASE CUP(s).
5. Uncover the cooking appliance and reconnect unit to electric power.

IMPORTANT:

DO NOT clean interior of ventilator by spraying.

Spraying can contaminate the cooking appliance, and may cause internal damage to the ventilator blower, operation proofing system and/or fire suppression system.

Clean by wiping only.

Procedure is complete

REQUIRED MAINTENANCE

USE AND MAINTENANCE SHALL BE IN ACCORDANCE WITH THE STANDARD FOR VENTILATION CONTROL AND FIRE PROTECTION OF COMMERCIAL COOKING OPERATIONS, N.F.P.A. 96 (current edition).

3-MONTH MAINTENANCE:

Thoroughly clean entire HOOD PLENUM and BLOWER section.

6-MONTH MAINTENANCE:

Inspection and testing of total operation including FIRE DAMPER and all SAFETY INTERLOCKS shall be performed by qualified service personnel.

All FIRE SUPPRESSION SYSTEM actuation components including MANUAL PULL STATION and any REMOTE MANUAL PULL STATION must be inspected for proper operation in accordance with the maintenance schedule published in ANSUL® R-102 SYSTEM DESIGN, INSTALLATION, RECHARGE AND MAINTENANCE MANUAL (418087).

ANNUAL (12-MONTH) MAINTENANCE:

NOZZLES and MANUAL PULL STATION must be cleaned in accordance with ANSUL® R-102 SYSTEM DESIGN, INSTALLATION, RECHARGE AND MAINTENANCE MANUAL (418087).

12-YEAR MAINTENANCE:

The FIRE SUPPRESSION AGENT TANK must be HYDROSTATICALLY TESTED, and the FIRE EXTINGUISHING AGENT must be REPLACED in accordance with the maintenance schedule published in ANSUL® R-102 SYSTEM (STANDARD UL 300 LISTED). This maintenance to be performed by qualified Ansul® service personnel only.

IMPORTANT:

Per NFPA 96, a signed and dated VENTILATOR HOOD MAINTENANCE LOG must be maintained on the premises, and be made available for inspection by the authority having jurisdiction upon request.

IMPORTANT:

Should the fire suppression system discharge, all lines and nozzles must be thoroughly cleaned prior to recharging the system.

Be sure to note such cleaning on the hood maintenance log. Residual fire suppression media may compromise the flow and dispersion of fire suppression media in any subsequent activation.

Inspection shall be conducted on a monthly basis in accordance with the manufacturer's Operation Manual. At a minimum, this inspection shall include verification of the following:

WELLS BLOOMFIELD, LLC
VENTILATOR HOOD OWNERS MONTHLY INSPECTION LOG

OPERATION	AGENT DATE												
Extinguishing system components: In proper place and (visually in good order													
Manual pull station actuators for fire suppression system are obstructed													
The maintenance log is in place and up to date													
No obvious physical damage or condition exists that might prevent operation of the fire suppression system													
The nozzle blow-off caps are in place and in good condition													
The hood, duct and protection cooking appliance have not been replaced, modified or relocated													
Clean plenum GREASE BAFFLE and BLOWER (max. interval: 3 months)													
Change PRE-FILTER and FILTER PACK (as required)													

II 2144

This MAINTENANCE LOG is to be performed and completed by a trained technician who has completed the instruction necessary to perform the maintenance and recharge service.

**WELLS BLOOMFIELD, LLC
VENTILATOR HOOD MAINTENANCE LOG**

OPERATION	AGENT / DATE												
Clean and inspect discharge nozzle in plenum BEFORE filters Max. interval: 6 months													
Clean and inspect discharge nozzle in plenum AFTER filters Max. interval: 6 months													
Inspect fire suppression detectors, all releasing devices for actuation, fire suppressant tank liquid level Max interval: 6 months (discharge of fire suppressant not a part of this test)													
Inspect fire suppression hoses, plumbing and tank for obstructions and any conditions such as, but not limited to, corrosion and pitting. Max. interval: 6 months													
Inspect and test all filter interlocks Max. interval: 6 months													
Replace fire damper fusible link: rated @ 280°F Max interval: 12 months	Log TEMP												
	Log Mfg DATE Stamp												

IL2798

THIS MAINTENANCE LOG MUST BE KEPT IN A PROTECTIVE COVER PERMANENTLY ATTACHED TO THE APPLIANCE Log all repairs and recommendations on reverse side. Any repairs, other than replacement of factory authorized parts, to the fire suppression plumbing system must be subject to hydrostatic pressure testing.

ANSULEX Low pH

QUICK IDENTIFIER (In Plant Common Name)

Manufacturer's Name:	ANSUL INCORPORATED	Emergency Telephone No.:	CHEMTREC (800) 424-9300 or (703) 527-3887
Address:	One Stanton Street, Marinette, WI 54143-2542	Other Information Calls:	(715) 735-7411
Prepared By:	Safety and Health Department	Date Prepared:	February 1, 1999

SECTION 1 - IDENTITY

Common Name (Used on Label): (Trade Name and Synonyms)	ANSULEX Low pH Liquid Fire Suppressant	CAS No.:	N/A
Chemical Name:	N/A This is a Mixture	Chemical Family:	Mixture
Formula:	N/A		

SECTION 2 - INGREDIENTS

PART A - HAZARDOUS INGREDIENTS				
Principal Hazardous Component(s) (chemical and common name(s)):	Wt. %	CAS No.	ACGIH TLV	Acute Toxicity Data
None	N/A	N/A	N/A	N/A
PART B - OTHER INGREDIENTS				
Other Component(s) (chemical and common name(s)):	Wt. %	CAS No.	ACGIH TLV	Acute Toxicity Data
Proprietary Mixture of Organic and Inorganic Salts	48.0 - 50.0	N/A	N/E	NDA
Phosphoric Acid	0.2	7664-38-2	N/E	NDA
EDTA	0.65	64--02-8	N/E	NDA
Yellow-Green Fluorescent Dye	0.011	518-47-8	N/E	Oral LD ₅₀ (rat) 6800 mg/kg
Water	Approx. 50.0	7732-18-5	N/E	NDA

SECTION 3 - PHYSICAL AND CHEMICAL CHARACTERISTICS (Fire and Explosion Data)

Boiling Point:	113°C	Specific Gravity (H ₂ O=1):	1.33	Vapor Pressure (mm Hg):	Not Determined
Percent Volatile by Volume (%):	Approx. 50.0	Vapor Density: (Air = 1):	1.03	Evaporation Rate: (Butyl Acetate=1):	Approx. 0.005
Solubility in Water:	100%	Reactivity in Water:	Mild exothermic reaction		
Appearance and Odor:	Fluorescent Yellow Colored Liquid, Mild Odor				
Flash Point:	None to boiling	Flammable Limits in Air % by Volume:	N/A	Extinguisher Media:	N/A
				Auto-Ignition Temperature:	N/A
Special Fire Fighting Procedures:	NONE - THIS IS AN EXTINGUISHING AGENT				
Unusual Fire and Explosion Hazards:	None				

SECTION 4 - PHYSICAL HAZARDS

Stability:	Unstable <input type="checkbox"/> Stable <input checked="" type="checkbox"/>	Conditions to Avoid:	N/A
Incompatibility (Materials to Avoid):	Reactive Metals, ClF ₃ , electrically energized equipment, any material reactive with water.		
Hazardous Decomposition Products:	Not established, acrid fumes.		
Hazardous Polymerization:	May Occur <input type="checkbox"/> Will Not Occur <input checked="" type="checkbox"/>	Conditions to Avoid:	N/A

M524 p/n 2M-Z17591 OpM WVU- Countertop Universal Hood

SECTION 5 - HEALTH HAZARDS

ANSULEX Low pH (continued)

Threshold Limit Value:	None Established		
Routes of Entry: Eye Contact:	Irritant		
Skin Contact:	Irritant		
Inhalation:	Not an expected route of entry. Can be irritating to mucous membranes.		
Ingestion:	Irritating to mucous membranes. Acute Oral LD ₅₀ (Sprague-Dawley rats) 825.5mg/kg.		
Signs and Symptoms:	Acute Exposure: Material irritates skin, eyes, and mucous membranes. Chronic Exposure: None known.		
Medical Conditions Generally Aggravated by Exposure:	None known.		
Chemical Listed as Carcinogen or Potential:	National Toxicology Program: Yes <input type="checkbox"/> No <input checked="" type="checkbox"/>	I.A.R.C Monographs: Yes <input type="checkbox"/> No <input checked="" type="checkbox"/>	OSHA Yes <input type="checkbox"/> No <input checked="" type="checkbox"/>

SECTION 6 - EMERGENCY AND FIRST AID PROCEDURES

Eye Contact:	Flush and irrigate with water for 15 minutes while holding eyelids open. If irritation persists, seek medical attention.
Skin Contact:	Wash thoroughly with soap and water. If irritation persists, seek medical attention.
Inhalation:	Fresh air if symptoms occur. If irritation persists, seek medical attention.
Ingestion:	Dilute by drinking large quantities of water.

SECTION 7 - SPECIAL PROTECTION INFORMATION

Respiratory Protection (Specify Type):	N/A		
Ventilation:	Local Exhaust: N/A	Mechanical (General):	N/A
Protective Gloves:	Rubber gloves for spill/leak	Eye Protection:	Chemical goggles recommended during spill/leak procedures.
Other Protective Clothing or Equipment:	Eye wash and safety showers are good safety practice.		

SECTION 8 - SPECIAL PRECAUTIONS AND SPILL/LEAK PROCEDURES

Precautions to be taken in Handling and Storage:	Store in original container. Keep tightly closed. Keep separate from acid.
Other Precautions:	See incompatibility information in Section 4.
Steps to be taken in Case Material is Released or Spilled:	Stop leaks. Contain spills. Remove as much as possible. Place in closed container for proper disposal Wash spill area with large amounts of water to remove traces and neutralize.
Waste Disposal Methods:	Dispose of in compliance with local, state and federal regulations.

HAZARDOUS MATERIAL IDENTIFICATION SYSTEM

HAZARD INDEX	
4 SEVERE HAZARD	0 HEALTH
3 SERIOUS HAZARD	0 FLAMMABILITY
2 MODERATE HAZARD	0 REACTIVITY
1 SLIGHT HAZARD	
0 MINIMAL HAZARD	

N/A = Not Applicable NDA = No Data Available N/E = Not Established

ANSUL and ANSULEX are registered trademarks.

Internet Address: <http://www.ansul.com>

ANSUL INCORPORATED, ONE STANTON STREET, MARINETTE, WI 54143-2542

Form No. F-90160-6

©1999 Ansul Incorporated

M524 p/n 2M-Z17591 Opm WVU- Countertop Universal Hood

TROUBLESHOOTING SUGGESTIONS

Problem	Possible Cause	Suggested Remedy
Unit will not operate (no indicators lights lit)	Disconnected from electric power	Reconnect to electric power Reset circuit breaker for unit
Unit will not operate (buzzer sounds)	Fire suppression system not set	Contact an authorized Ansul® distributor for repairs
CHECK FILTER light lit	Filter pack, Pre-filter or baffle filter not in position	Properly install filters
REPLACE FILTER light lit	Filter nearing end of service life	Arrange to replace filters in a timely manner
SERVICE REQUIRED light lit (cooking appliance not operating)	Filter pack plugged	Replace filter pack
	Fire damper in exhaust collar has closed	Contact an authorized Wells service agent for repairs
	One or more vacuum sensing lines or ports plugged, or sensing line dislodged.	Contact an authorized Wells service agent for repairs
	NOTE: If, after 20 seconds, there is insufficient airflow for proper operation, SERVICE REQUIRED light will illuminate and under-hood appliance (s) will be de-energized. Press VENTILATOR POWER SWITCH to <i>OFF</i> , then back to <i>ON</i> to reset system.	

NOTE:

FILTERS are the only user serviceable components in this ventilator hood system. For all problems that cannot be remedied by servicing the filters, contact:

- Ventilator section - authorized Wells service agency
- Fire suppression system - authorized Ansul® distributor

IMPORTANT:

Contact ANSUL® for fire suppression system installation, set-up and service:

Ansul Incorporated 1-800-TO-ANSUL (1-800-862-6785)
 One Station Street
 Marinette, WI 54143-2542 website <http://www.ansul.com>

IMPORTANT:

Parts used in the Ansul® fire suppression system are not serviceable by the owner/operator.

Procedures for servicing fire suppression equipment are described in:

ANSUL® R-102 SYSTEM DESIGN, INSTALLATION, RECHARGE AND MAINTENANCE MANUAL
 (418087, current edition)

NOTE:

ANSUL® Manual 418087 is intended for use by authorized Ansul® service personnel only.

WIRING DIAGRAM

M524 p/n 2M-Z17951 OpM WVU- Countertop Universal Hood

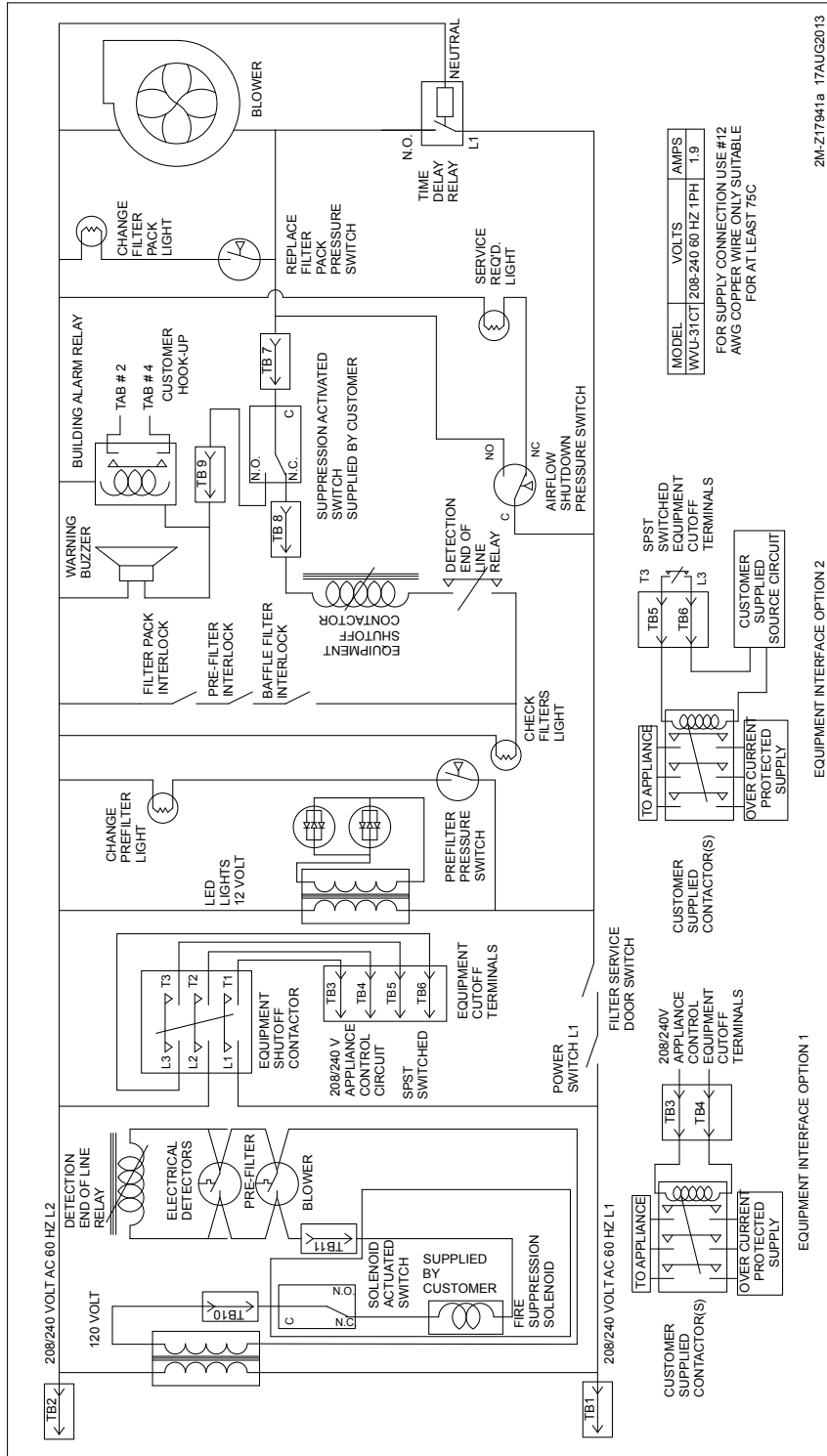

EXPLODED VIEW & PARTS LIST

Filter Maintenance

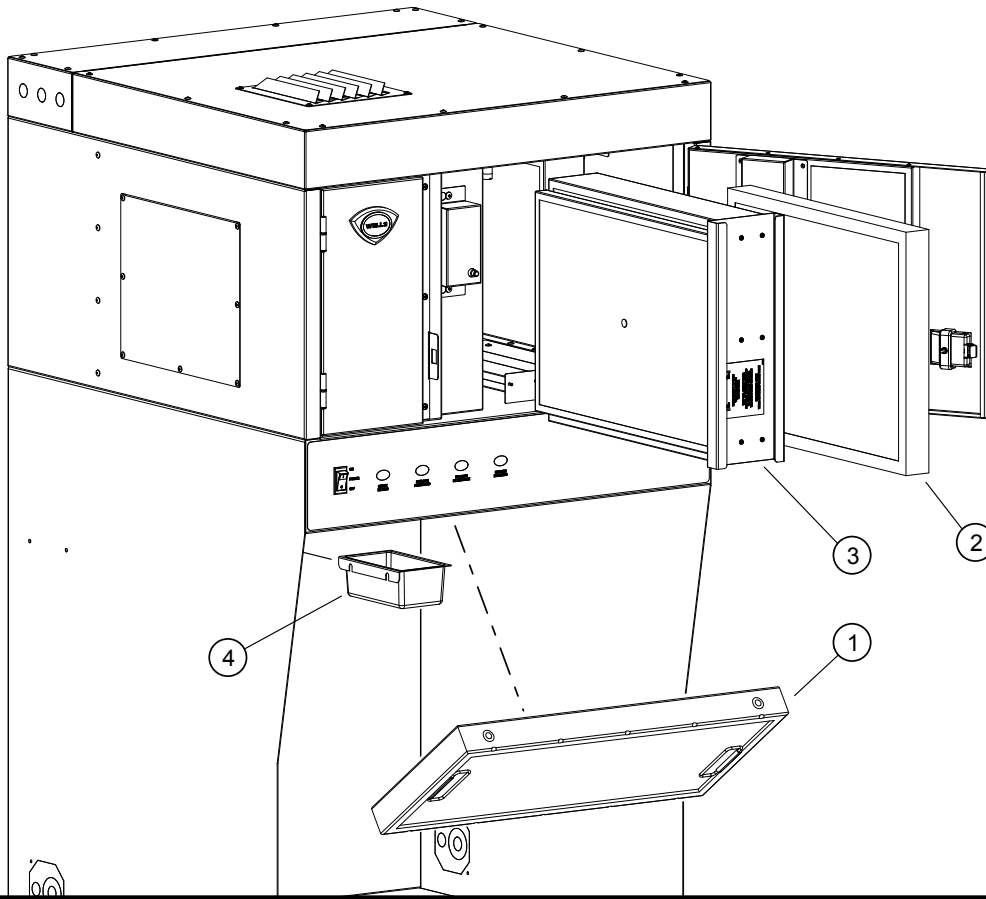

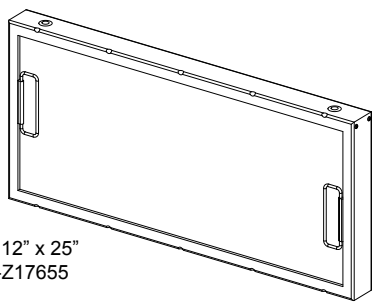
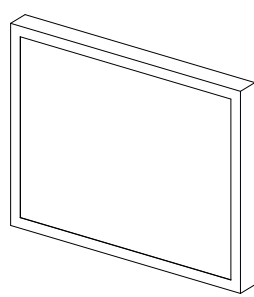
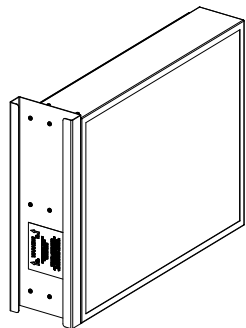
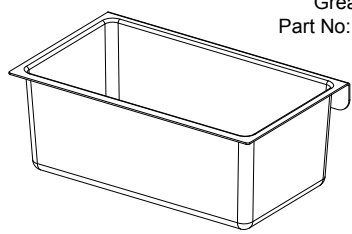
<p>①</p>  <p>Baffle Filter: 12" x 25" Part No: 2I-Z17655</p>	<p>②</p>  <p>Pre-Filter Hood Part No: 2I-302579</p>
<p>③</p>  <p>Filter HEPA/Carbon Pack Part No: N1-WL0422</p>	<p>④</p>  <p>Grease Cup Part No: 2D-Z14672</p>

Model: WVU-31CT Maintenance Parts

SK2747 Rev. a, 4/16/2014

M524 p/n 2M-Z17951 OpM WVU- Countertop Universal Hood

EXPLODED VIEW & PARTS LIST

Suppression System

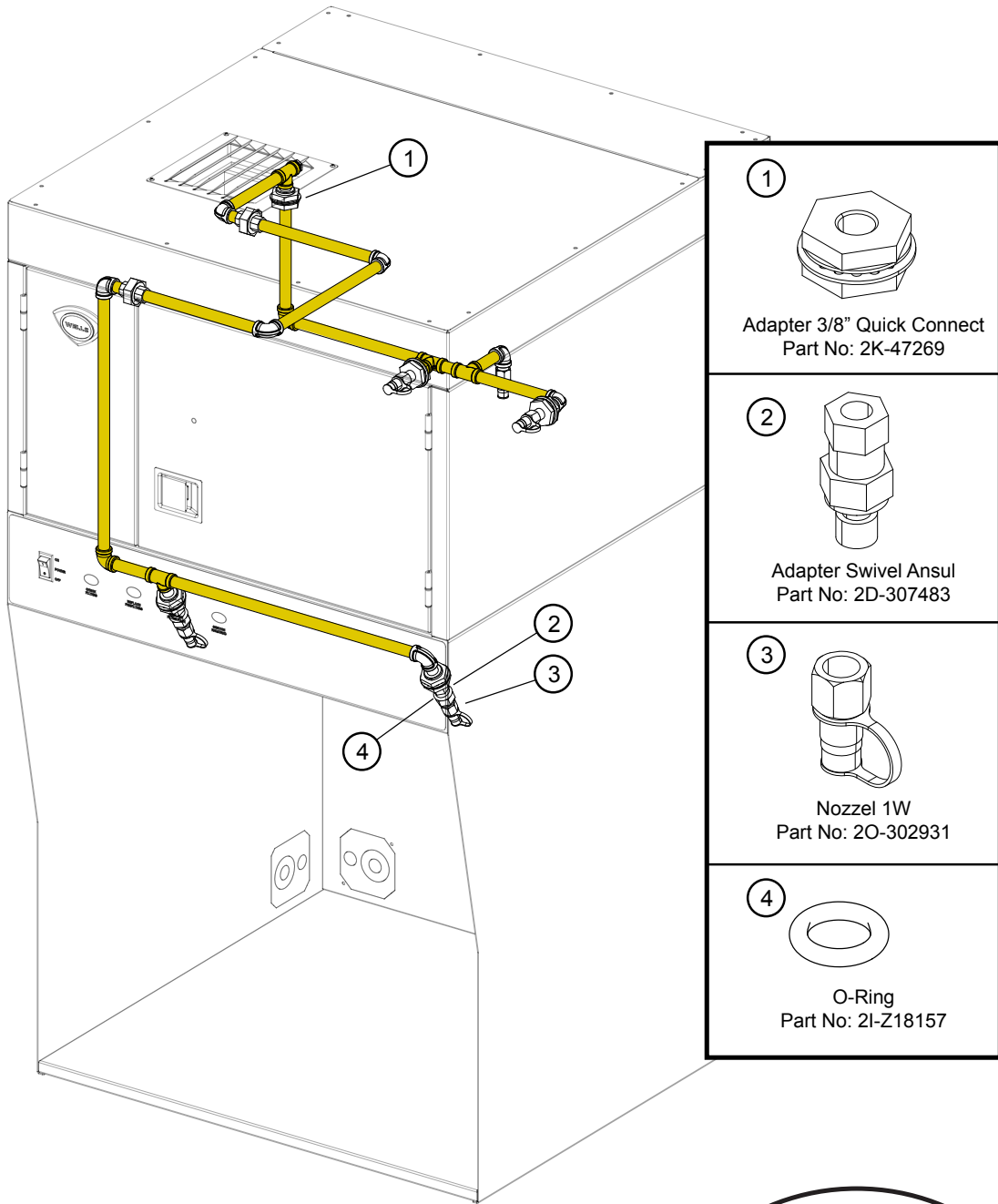

M524 p/n 2M-Z17951 OpM WVU- Countertop Universal Hood

Model: WVU-31CT Suppression System

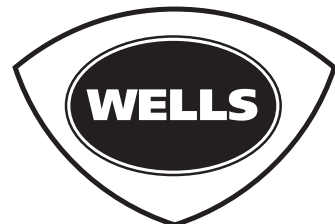

SK2748 Rev. A, 4/17/2014

EXPLODED VIEW

Main Assembly

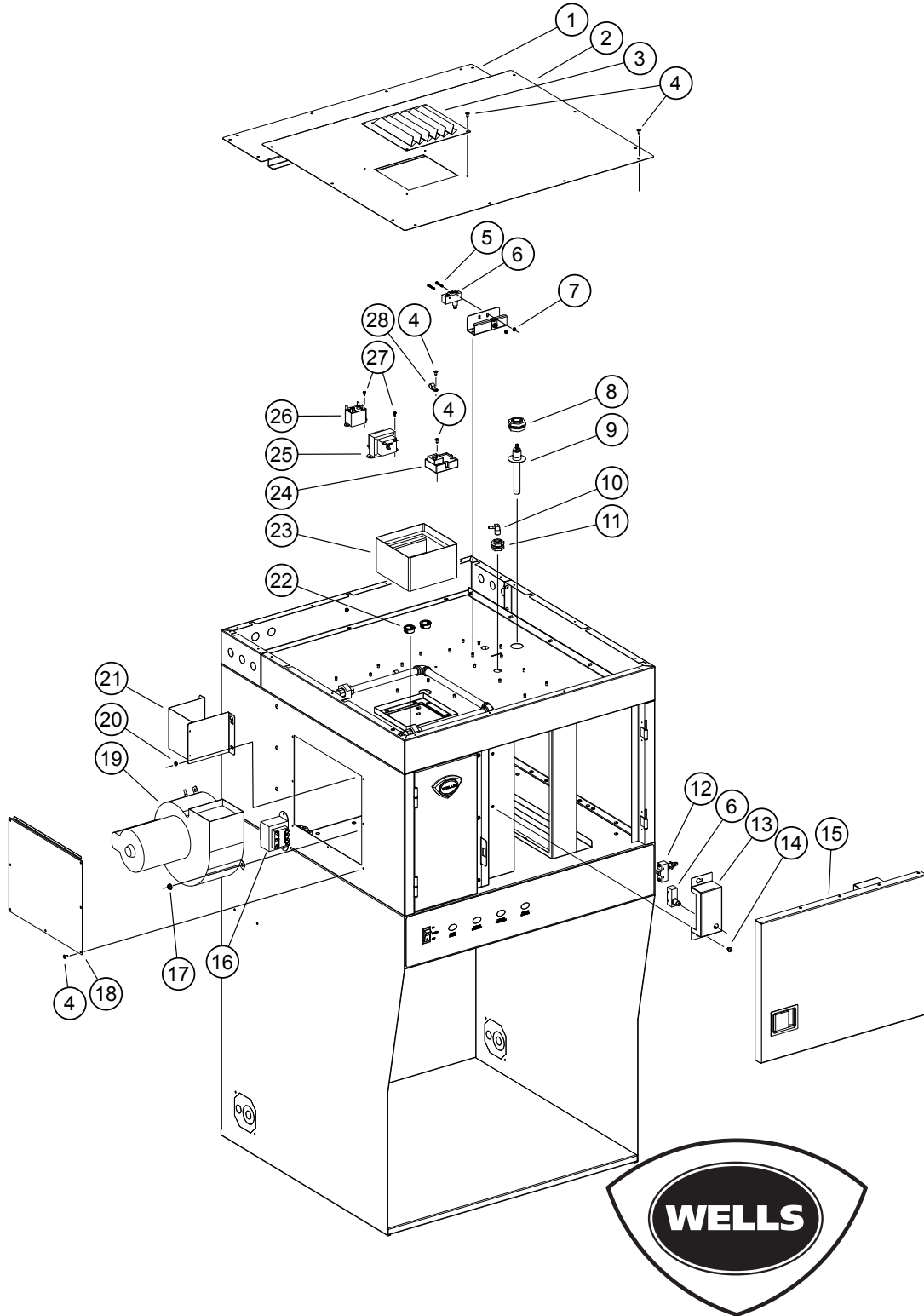

Model: WWU-31CT Main Assembly

SK2750 Rev. A, 4/22/2014

M524 p/n 2M-Z17951 OpM WWU- Countertop Universal Hood

PARTS LIST

Main Assembly

Model: WVU-31CT Main Assembly			
Fig No	Part Number	Quantity	Description
1	N1-Z17756	1	TOP COVER PANEL, REAR
2	N1-Z17755	1	TOP COVER PANEL, FRONT
3	N1-Z17687	1	AIR DEFLECTOR PLATE
4	2C-6349	32	SCREW #8X3/8 B THP STL NP
5	2C-42066	2	SCREW 6-32X1 PH RD HD NI
6	2E-Z12427	2	SWITCH, SPDT (DOOR)
7	2C-200201	2	NUT 6-32 HEX LOCK SS
8	2K-Z15319	2	ADAPTOR 1/2" QUICK SEAL
9	2T-Z15320	2	THERMAL DETECTOR-225F
10	2K-Z15502	2	FTG,90DEG ELBOW,3/16"X1/4
11	2K-47100	2	ADAPTER 1/4IN QUICK CON A
12	2E-300407	2	FILTER SW,PLUNGER W/ RLLR
13	N1-Z17679	1	COVER BKT,PLUNGER SWITCH
14	2C-42067	2	SCREW 10-32X3/8 PH TR HD
15	N1-WL0479	1	FILTER DOOR ASSY,RIGHT
16	2E-Z15335	1	TRANSFORMER 208/240 100VA
17	2C-6517	3	NUT 1/4-20 HEX STL NP
18	N1-Z17690	1	PLATE,SIDE ACCESS
19	2U-302584	1	BLOWER ASSY UNIVERSAL HD
20	2C-Z7165	16	NUT 8-32 HEX SS W/EXT WSH
21	N1-WL0416	1	DISCHARGE SPOUT ASSY
22	2K-Y5093	5	BUSHING-SNAP #SB-1000-12
23	2V-302582	1	DAMPER FIRE 6x6, 282'F
24	2P-Z17415	1	TIMER,CUBE/ RELAY
25	2E-Z15018	1	TRANSFORMER, 208/240 12V
26	2E-Z15353	1	RELAY, 120V SPNO
27	2C-303522	6	SCREW 6X3/8 PH PAN DRLPT
28	2C-Z18059	6	CABLE CLAMP NYLON 1/2 DIA

EXPLODED VIEW

Controls Assembly

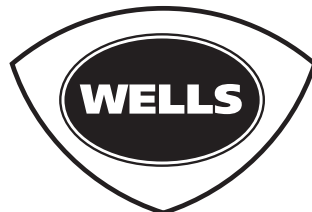
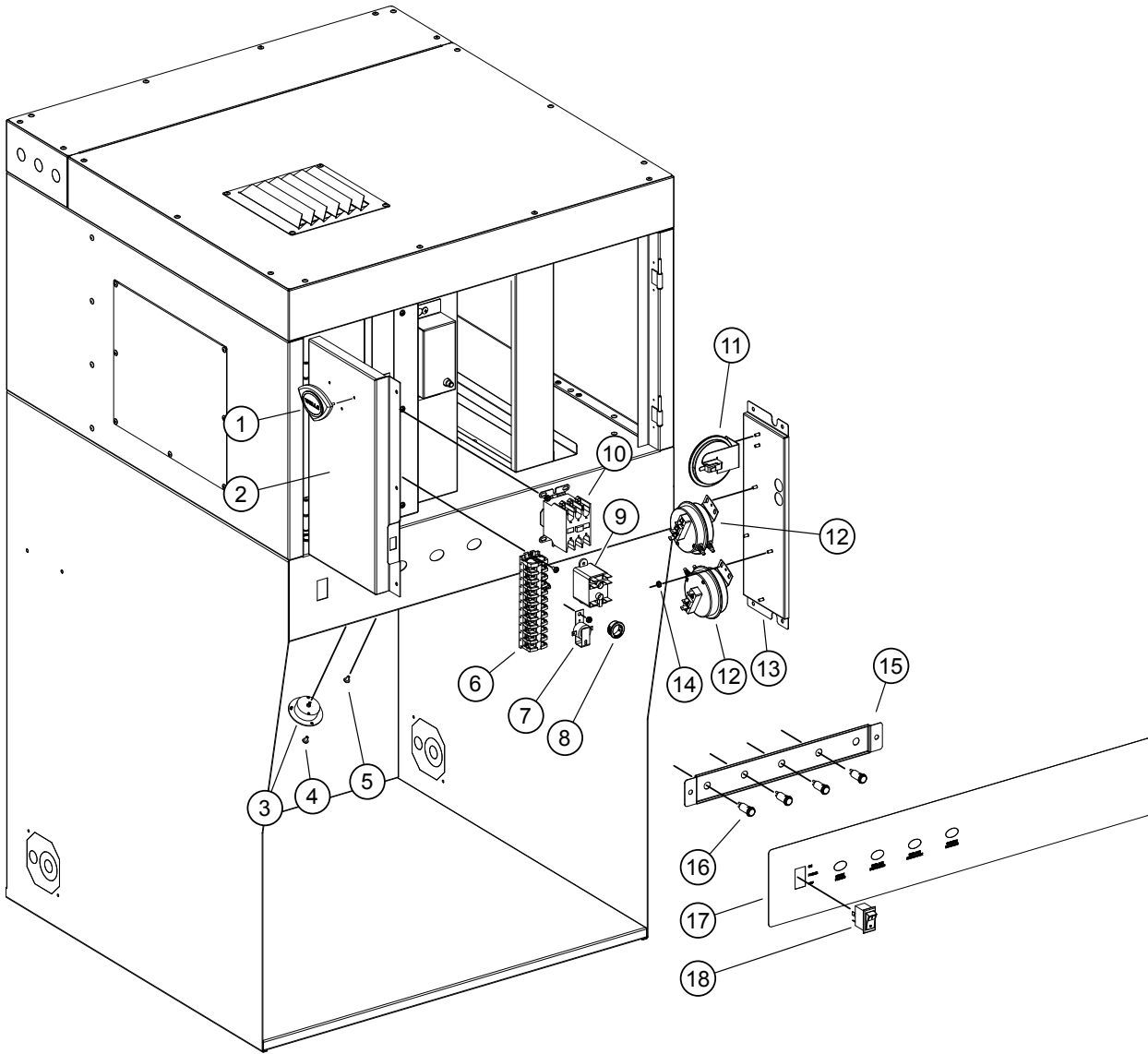

Model: WVU-31CT Controls Assembly

SK2751 Rev. A, 4/22/2014

M524 p/n 2M-Z17951 OpM WVU- Countertop Universal Hood

PARTS LIST

Controls Assembly

Model: WVU-31CT Control Assembly			
Fig No	Part Number	Quantity	Description
1	2M-306719	1	LOGO WELLS DIECAST SHIELD
2	N1-WL0480	1	DOOR ASSEMBLY, LEFT
3	N1-WL0245	2	LED LIGHT W/TERMINALS
4	2C-Z14619	6	SCREW 4-40X1/4 PH PAN HD
5	2C-200014	42	SCREW 8-32X3/8 THP SS
6	N1-Z18155	1	TERMINAL BLOCK ASSY
7	2J-44834	1	BUZZER 220V ROHS
8	2K-Y5093	5	BUSHING-SNAP #SB-1000-12
9	2E-44514	1	RELAY 208-240V COIL
10	2E-Z14960	1	CONTACTOR,40A 208/240COIL
11	2E-Z24056	1	SWITCH VACUUM #2
12	2E-Z15352	2	VACUUM SWITCH,HEPA FILTER
13	N1-Z17683	1	MOUNTING PLATE,PRESSURE
14	2C-Z7165	6	NUT 8-32 HEX SS W/EXT WSH
15	N1-Z15418	1	MOUNTING PLATE,CTRL LIGHT
16	N1-WL0737	4	LIGHT SIGNAL ASSY, CLEAR LED
17	2M-Z17758	1	GRAPHICS PANEL - WVU-31CT
18	2E-305295	1	SWITCH ROCKER 250V 10A GR

Ansul® Parts For 31CT To Be Supplied By Customer

The following parts are to be procured by customer and installed by ANSUL® authorized distributor. **This list does not include the conduit and fittings that may be required for the Ansul plumbing.**

Model: WVU-31CT Control Assembly			
Wells Part Number	ANSUL® Part Number	Description	Qty Rqd. 31CT Model
Actuators, hoses, and fittings required			
2E-47273	423878	One Electric Switch Kit (Field Mounted) Includes Electric Switch (SPDT), and Mounting Hardware	1
2K-301245	Included (79153)	COMPRESSION SEAL 1/2 EMT	3
2O-Z15341	415054	OEM Regulated Electric Release Shipping Assembly Includes Release Mechanism, and ¼ in. Hose and Mounting Bracket	1
Nitrogen Cartridges Required			
2O-47099	423429	Cartridge Shipping Assembly (LT-20-R)	1
ANSULEX Tanks and ANSULEX Required			
2O-304433	429864	1.5 Gallon Tank Shipping Assembly	1
2O-47469	79694	1.5 Gallon Container of ANSULEX Low pH Liquid Fire Suppressant	2
Nozzles and Nozzle Components Required			
All included			
Manual Pull Station Parts Required			
2O-47272	423251 (50 in package)	Pulley Elbows Shipping Assembly (Compression End)	? (6)
N1-Z15506	434525	Flexible Conduit (500 ft.)	? (6 ft.)
2A-47470	26317	Stop Sleeve	1
2K-Z15507	435979	Flexible Conduit Strain Relief	2
2K-Z15508	434347	Flexible Conduit Inserts	2
2O-301164	4596	Oval Press-To-Crimp Sleeves	1
2O-308131	434618	Remote Manual Pull Station	1
2O-47466	79653 or 15821	1/16 in. Stainless Steel Cable. ANSUL part no. 79653 is 500 ft. ANSUL part no. 15821 is 50 ft.	? (20 ft.)

PARTS & SERVICE

DESCRIPTION

PART NO.

IMPORTANT: Use only factory authorized service parts and replacement filters.

For factory authorized service, or to order factory authorized replacement parts, contact your Wells authorized service agency, or call:

Wells Manufacturing
10 Sunnen Dr.
St. Louis MO 63143 USA

Service Dept.
phone: (800) 264-7827

Service Parts Department can supply you with the name and telephone number of the WELLS AUTHORIZED SERVICE AGENCY nearest you.

CUSTOMER SERVICE DATA

please have this information available if calling for service

RESTAURANT _____ LOCATION _____

INSTALLATION DATE _____ TECHNICIAN _____

SERVICE COMPANY _____

ADDRESS _____ STATE _____ ZIP _____

TELEPHONE NUMBER (____)____-_____

EQUIPMENT MODEL NO. _____ EQUIPMENT SERIAL NO. _____

VOLTAGE: (check one) 208 240



Wells proudly supports CFESA
Commercial Food Equipment Service Association

SERVICE TRAINING - QUALITY SERVICE



CUSTOMER SATISFACTION



WELLS MANUFACTURING

265 Hobson Street, Smithville, Tennessee 37166

telephone: 800-264-7827

www.wells-mfg.com